



TYPE DL-1-110

HEAVY DUTY SUBMERSIBLE PUMPS

*INSTALLATION,
OPERATION &
MAINTENANCE
INSTRUCTIONS*

TOYO PUMPS NORTH AMERICA CORPORATION

2853 Douglas Road
Burnaby, British Columbia
CANADA V5C 6H2

Telephone: (604) 298-1213
Fax: (604) 298-7773
Email: info@toyopumps.com

INTRODUCTION

Thank you for selecting the Toyo submersible pump.

In order to ensure that you receive the maximum benefit of this equipment, it is required that this INSTRUCTION & SERVICE MANUAL be thoroughly read prior to use, and that all instruction be carefully followed.

WARNING!!

<p>This is not explosion-proof or spark-proof. It should not be operated in any area where flammable or explosive gases, vapors, liquids or particles are or may be present or where a spark could cause a danger or fire or explosion.</p>

These ruggedly built, portable, electrically powered submersible pumps are designed for trouble-free operation in the removal of water from enclosed sumps, irrigation areas or serve a variety of general dewatering/pumping chores (applications).

The pumps feature an oil-filled chamber between the pump section and the electric motor section that has a high efficiency sealing system.

This sealing system prevents water from entering the motor and also permits extended dry running without the concern for seal damage.

These pumps are also equipped with induction-type motors that have built-in overload protection to guard against motor burn out due to over-current, over-heating or other mechanical over-load conditions.

Please fill in the information below and retain. These information will be necessary when requesting parts or service.

PUMP MODEL	DL -1-110
SERIAL NO.	
DATE OF PURCHASE	

**TOYO SUBMERSIBLE PUMP
MODEL DL-1-110**

OPERATING & MAINTENANCE INSTRUCTIONS

PRIOR TO OPERATION

1) UNPACKING AND INSPECTION

- a) Always lift the pump by the handle-not the cabtyre cable.
If the pump must be suspended in a well or pit, a rope or chain should be attached to the pump handle.
- b) Check the nameplate information to ensure that the equipment received is that which was ordered.
- c) Carefully inspect the pump to be sure that shipping damage has not occurred.

2) INSPECTION OF PUMP

- a) Check to determine that the power circuit and/or receptacle are adequate to handle voltage/current rating of the motor-pump.
- b) Ensure that cabtyre cable/extension cord is free from damage and that grounding wire/circuit is operational.

CAUTION: Do not operate this pump unless it is connected to a properly wired grounding circuit since serious personal injury may result from electrical shock. Disconnect the cabtyre cable from the power source, before servicing this pump.
Do not use this pump in the water where person(s) is (are).

INSTALLATION & OPERATION

- a) Be certain that the pump is mounted on a solid, flat base or suspended by a rope or chain attached to the pump handle.

CAUTION: Do not use the electrical cable or discharge hose to suspended the pump.
Always attach suspension rope to the pump handle.

- b) Use the shortest possible length of discharge hose to assure you minimize friction losses and maximize your pump flow.
- c) Make certain that the cable and/or receptacle from which it draws power is protected and away from water or pump discharge hose to prevent accidental shock or electrical short circuiting.
- d) The pump model has a built-in overload protector which senses over-current, over-heating, or over-load conditions.
The operation of this protector is such that should any of these conditions exists, the power supply will be interrupted until motor cooling has taken place. After cool-down has occurred, the pump will automatically re-start and continue to be protected in this way as long as the condition exists, but we request you to check and remove the cause.

Note: This is a protection device and is not intended to replace external controls.

- e) When cable extension is necessary, extended cable size must be adequate to avoid low voltage conditions, which may cause motor burn out. Select the proper gauge size and minimize length of the extension cable not to cause a large voltage drop. If you are not sure, it is recommended to consult with the Toyo representative office or Toyo suppliers nearest you. When extending the cable, be careful not to submerge the splice into the water to avoid the possibility of electrical shock.

- f) Connection to Power Source
DL-110: Plug in or connect to one phase power source.

CAUTION: Be sure to provide an adequate grounding and to use a ground leakage circuit breaker.

AFTER OPERATION

To keep the pump in good condition and maintain high pumping efficiency the following inspections should be carried out after each fifty (50) hours of operation. (See Fig.A6470)

- a) Remove Strainer-stand (item #23) and Pump Casing (#20). Clean out any solids and/or mud, sand, stones or other foreign material which may have collected in the Pump Casing.
- b) Check the Impeller (#21) for wear, obstruction or foreign material accumulation. If parts are extremely worn, replacement should be made at the first opportunity.
- c) After the inspections, clean the inside and outside of pump with clean water. When it is stored, keep it in a dried condition.

REGULAR INSPECTION

1) LUBRICANT CHECK (See Fig.A6470)

Check the mechanical seal by inspecting the condition of the lubricant in the oil chamber. You may readily determine the condition of the mechanical shaft seals based upon contamination level in the oil.

- a) Lay the pump on its side with Oil Plug (#35) facing upwards.
After unscrewing the plug, turn the pump over so that the hole faces downward. Drain and collect the lubricant in a clean suitable container.
- b) If the lubricant is clear and clean (not milky appearing or no water present), the seals should be in a good condition.
- c) Refill the chamber with fresh lubricant, using a good multiviscosity grade lubricant (Turbine Oil ISO VG #32).
- d) Extreme discoloration (milky appearing or yellowish-gray) or free water in the lubricant requires immediate replacement of Mechanical Seal (#25) and V- Ring(#26).
- e) When inspection is complete, replace the oil plug and carefully tighten to prevent leakage.

Note: Replace Packing of the oil plug, if it is found to be defective.

Periodic inspection and replacement of the oil should be made as follows:

*Inspection Cycle: Every 1,000 hours of running time

*Replacement Cycle: Every 2,000 hours of running time

But we recommend inspection once a year even if running time is less than above.

Required lubricant volume is as follows and recommended lubricant is Turbine Oil ISO VG # 32. For your convenience, other lubricants equivalent to ISO VG # 32 are listed as follows.

If it is difficult to get these turbine oils, engine-oil (10W-30/40) can be used alternatively.

MODEL	Lubricant VOLUME			TYPE	BRAND NAME
	METRIC	OZ	US		
DL-1-110	0.147 (liter)	4.97 (oz)	0.31 (pint)	DTE Oil Light Victoria Oil 27 Energol THB 32 Paramount 32	Mobil Shell British Petroleum Gulf

2) ELECTRICAL CHECK (MEGGER TEST)

Whenever the pump is serviced, it is a good maintenance/safety practice to check the insulation strength of the motor and cabtyre cable in the following manner to prevent electrical shock accident(s).

- a) Disconnect the cabtyre cable from the power source.
- b) Using the 500 VDC Megger Tester, check the electrical insulation of each leg of the wiring circuit in combination with the ground lead (green or green/yellow).
- c) If any reading is less than one (1) meg-ohms (M<), it indicates damage to the cabtyre cable and/or the motor.
- d) Disconnect the cabtyre cable from the motor and Megger Test the insulation strength of the motor itself.
- e) Any reading more than ten (10) meg-ohms (M<) requires immediate replacement of the Cabtyre Cable.
Any reading less than ten (10) meg-ohms (M<) indicates electrical leakage due to the presence of water or dampness in the motor in which case the motor must be dried thoroughly.
If after drying, the condition still exists, there is a strong probability that the motor is in need of repair.

CAUTION: It is absolutely imperative that appropriate corrective action/repair be performed before the pump is returned to service if it will not pass the Megger Test. Serious personal injury can result from electrical shock. The above maintenance inspection, if it is performed regularly, will result in greatly improved pumping efficiency and pump life.

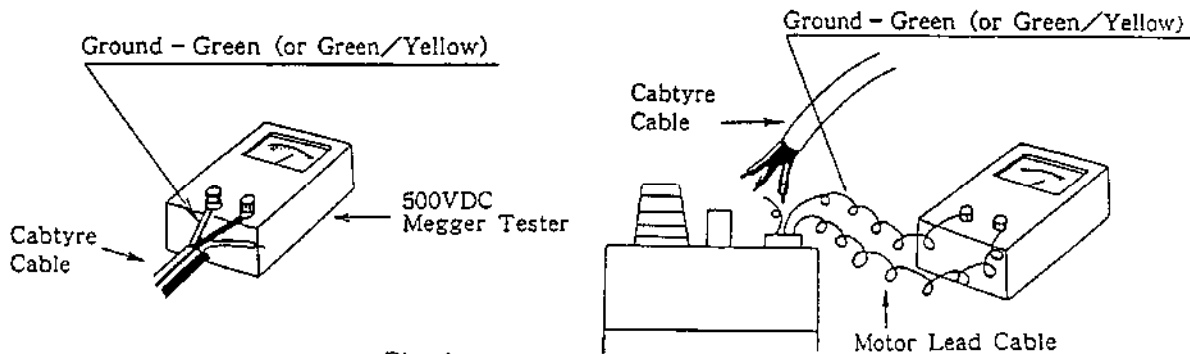
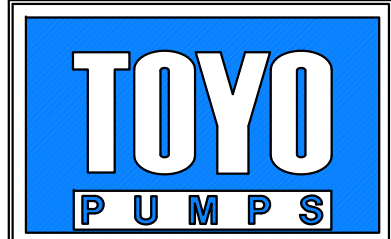
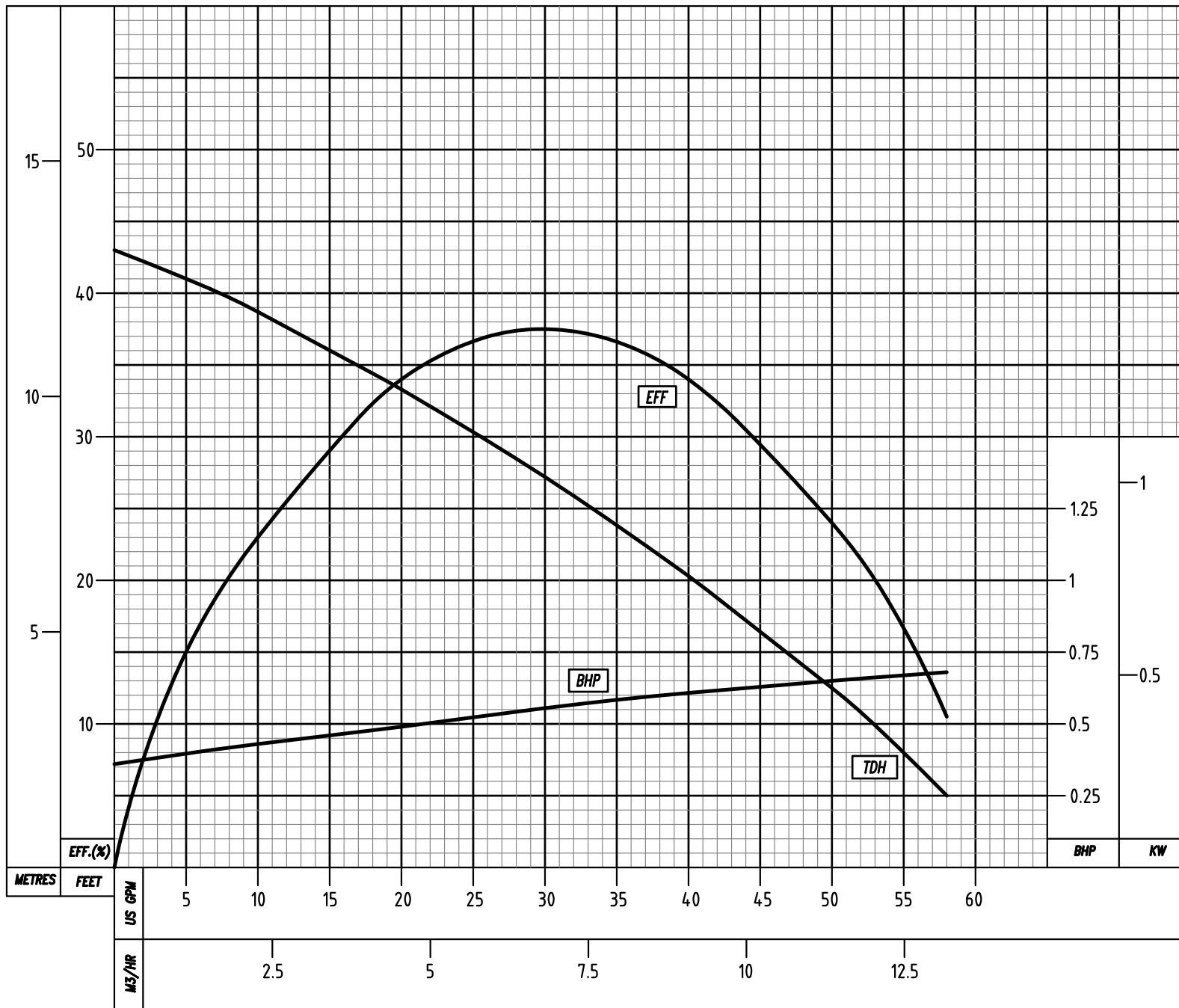

Fig. 1

TROUBLE SHOOTING

FAULT	POSSIBLE CAUSES	CORRECTION
Pump will not start.	<ol style="list-style-type: none"> 1. No electric power. 2. Cable cut/broken. 3. Poor electric connection. 4. Low voltage. 5. Impeller obstructed. 6. Overload relay actuated. 	Turn power on. Change cable. Clean connection. Check power source. Remove obstruction. Wait for motor to cool down.
Stop during operation.	<ol style="list-style-type: none"> 1. Impeller obstructed. 2. Overload relay actuated. 3. Low voltage. 4. Liquid viscosity too high. 	Remove obstruction. Wait for motor to cool down. Check power source. Reduce viscosity.
Reduction in Capacity	<ol style="list-style-type: none"> 1. Discharge hose kinked or otherwise obstructed. 2. Impeller worn. 3. Strainer blocked. 	Remove kink or obstructed. Change worn parts. Remove obstruction.

CAUTION: Disconnect the cabtyre cable from the power source, before servicing pump.



WWW.TOYOPUMPS.COM

TOYO PUMPS NORTH AMERICA CORPORATION
 BURNABY, BRITISH COLUMBIA
 CANADA V5C 6H2
 TEL : (604)298-1213 FAX : (604)298-7773

PUMP MODEL	DL1		
CURVE NUMBER	A6468	REV.	1
EFFECTIVE DATE	APR 29 2008		
SUPERSEDES	A6468	REV.	0

DISCHARGE	INCHES	2
	MM	50
SUCTION	INCHES	-
	MM	-
TEST NUMBER	-	

IMPELLER NBR	021-001-34	
IMPELLER TYPE	OPEN	
IMP. DIAMETER	INCHES	3.4
	MM	85
MAX.PARTICLE	INCHES	0.4
	MM	10
VOLUTE NUMBER	020-000-40	

MOTOR OUTPUT	HP/KW	0.75/0.55
PHASE x VOLTAGE	SINGLE X 110V	
RATED CURRENT	AMPS	7.6
WINDING INSULATION CLASS	E	
POLES/REVOLUTION	2 P / 3380 RPM	

PERFORMANCE FOR WATER @ 68°F/20°C
 AND 1.0 S.G. CORRECT FOR OTHER
 CONDITIONS AND/OR SOLIDS EFFECT

DL1 SERIES SEMI-VORTEX - DEWATERING PUMP

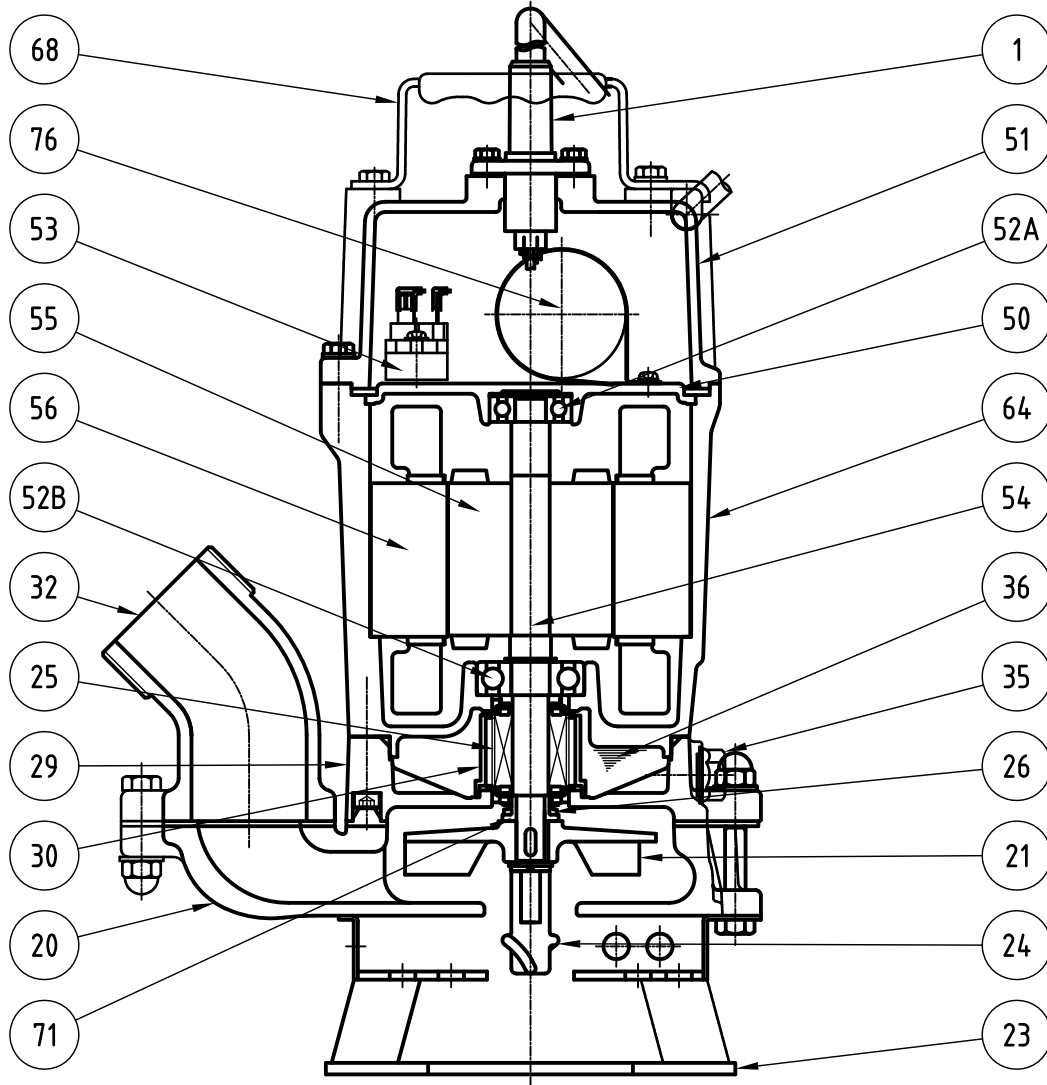

No.	DESCRIPTION	QTY	MATERIAL / NOTE	No.	DESCRIPTION	QTY	MATERIAL / NOTE
1	CABTYRE CABLE	1	PVC SHEATH AWG16/3-32ft	51	MOTOR HEAD COVER	1	B85, A383
20	PUMP CASING	1	A536 GRADE 100-70-03	52A	UPPER BEARING	1	6201ZZC3
21	IMPELLER	1	A532 CLASS III TYPE A	52B	LOWER BEARING	1	6302ZZC3
23	STRAINER STAND	1	STEEL	53	MOTOR PROTECTOR	1	
24	AGITATOR	1	A532 CLASS III TYPE A	54	SHAFT	1	AISI 403
25	MECHANICAL SEAL	1	SILICON CARBIDE / W-14VL	55	ROTOR	1	
26	V-RING	1	NBR	56	STATOR	1	
29	OIL CASING	1	CAST IRON	64	MOTOR HOUSING	1	B85, A383 (ALUMINUM ALLOY)
30	OIL LIFTER	1	ABS RESIN	68	HANDLE	1	A109 CLASS 91
32	DISCHARGE CONNECTION	1	CAST IRON 2" NPT	71	SHAFT SLEEVE	1	AISI 304
35	OIL PLUG	1	STAINLESS STEEL	76	CAPACITOR	1	
36	LUBRICANT		TURBINE OIL ISO VG32 OR SAE 10W/20W				
50	MOTOR BRACKET	1	ADC12				

TOYO
PUMPS

TOYO PUMPS
NORTH AMERICA CORPORATION

CROSS-SECTIONAL DRAWING
DL1-110

DRAWING NO.
A6470

REV.
2

DL1 SERIES SEMI-VORTEX - DEWATERING PUMP

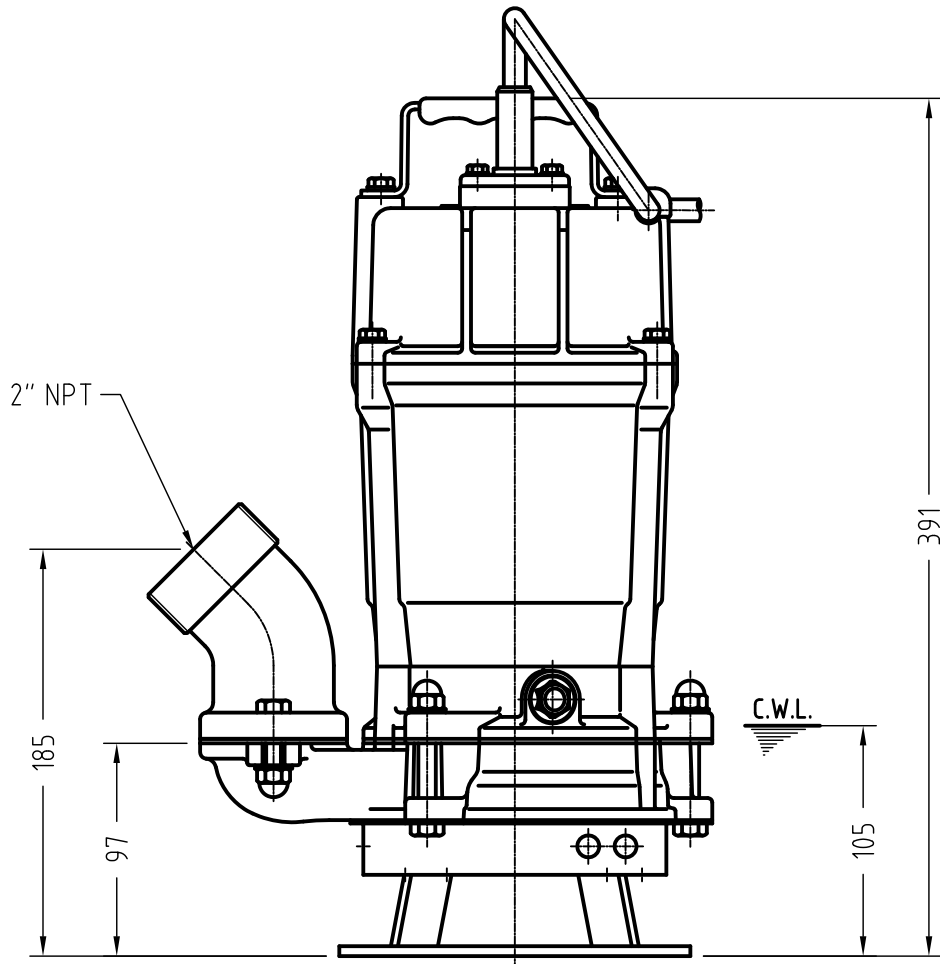
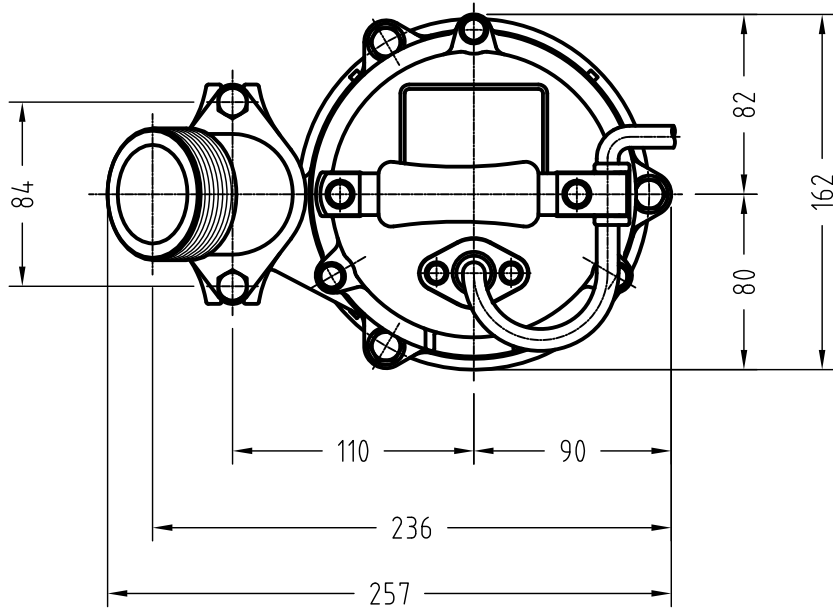

TOYO
PUMPS

TOYO PUMPS
NORTH AMERICA CORPORATION

DIMENSIONAL DRAWING
DL1-110

DRAWING NO.
A6469

REV.
1

DL1 SERIES SEMI-VORTEX – DEWATERING PUMP

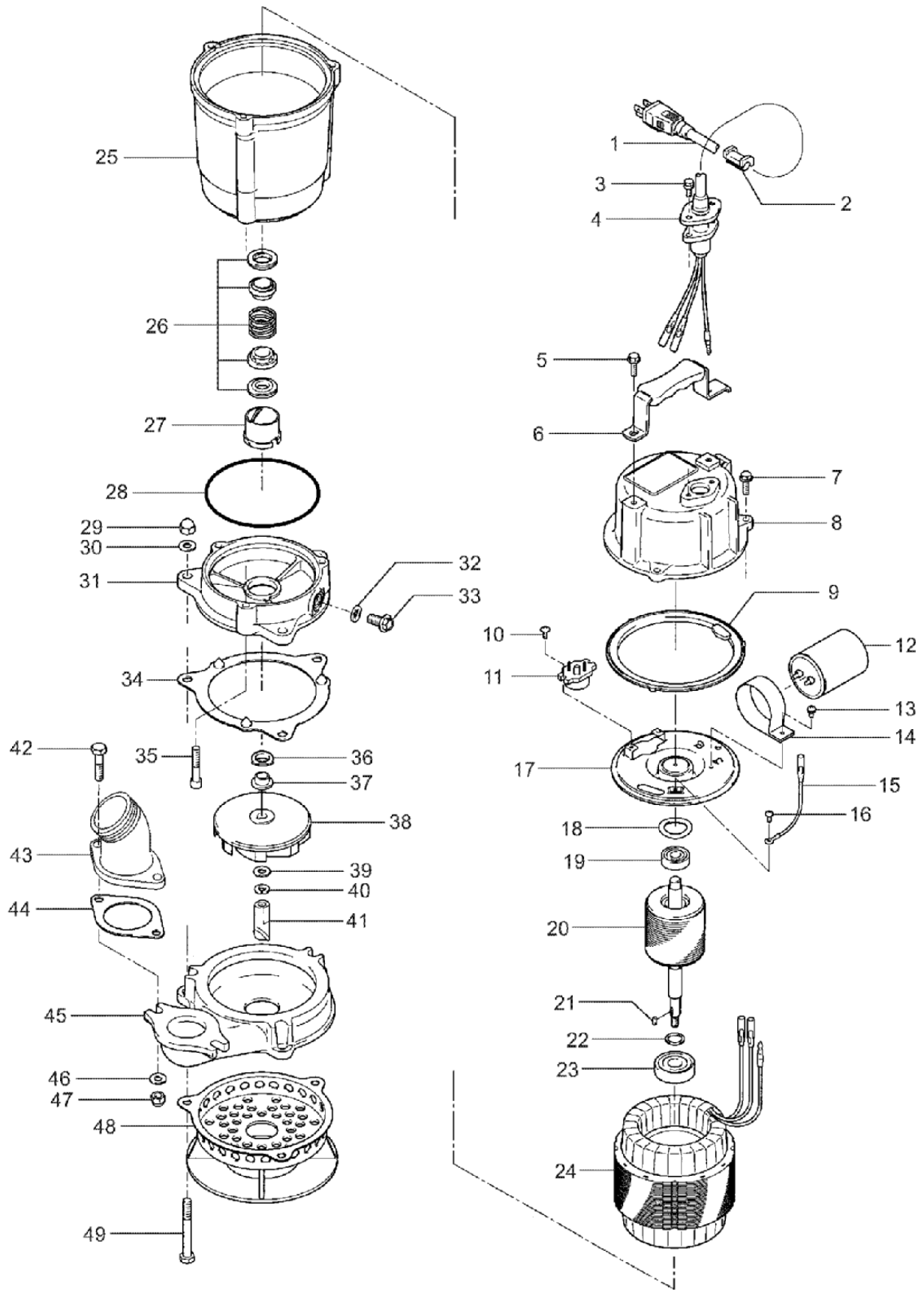

TOYO PUMPS
NORTH AMERICA CORPORATION

EXPLODED VIEW
DL1-110

DRAWING NO.
A6763

REV.
1



TOYO PUMPS NORTH AMERICA CORPORATION

2853 Douglas Road
 Burnaby, BC V5C 6H2
 Tel: (604) 298-1213 Fax: (604) 298-1224

Kit ITEMS ARE INCLUDED IN GASKET KIT
 SR ITEMS ARE INCLUDED IN SEAL REPAIR KIT

PARTS LIST - DL1-110

Ref. Dwg. No. A6763 Rev.1

TPSD-001 Rev.0

Please use the part number when ordering.

Effective: June 29, 2009

	REF #	PART #	DESCRIPTION	QTY
	1	001-943-23	Power Cable 32'	1
	2	010-163-16	Cable Clip Rubber	1
	3	040 415 00 08105	Bolt	2
	4	003-100-13	Gland	1
	5	040 415 00 13900	Bolt	2
	6	068-224-15	Handle	1
	7	140-396-16	Bolt	3
	8	051-000-10	Motor Head Cover	1
Kit	9	121-546-14	Gasket (H.Cover/M.Frame)	1
	10	143-136-15	Truss Screw	2
	11	053-000-63	Motor Protector 110/115/120V-60HZ	1
	12	076-000-18	Capacitor 110/115/120V-60HZ	1
	13	143-085-21	Pan Screw	1
	14	127-000-12	Retainer (Capacitor)	1
	15	009-000-44	Grounding Wire	1
	16	143-203-14	Pan Screw	1
	17	050-000-10	Motor Bracket	1
	18	142-192-16	Wave Washer	1
	19	052-100-15	Ball Bearing (Upper)	1
	20	055-000-92	Rotor and Shaft	1
	21	147-168-18	Key	1
	22	061-178-12	Bearing Collar	1
SR	23	052-152-12	Ball Bearing (Lower)	1
	24	056-002-03	Stator 110/115/120V-60HZ	1
	25	064-000-50	Motor Frame	1
SR	26	025-291-10	Mechanical Seal	1
SR	27	030-159-11	Oil Lifter	1
Kit	28	122-133-17	O-Ring (M.Frame/O.Casing)	1
	29	141-030-12	Acorn Nut	3
	30	142-143-12	Washer	3
	31	029-000-17	Oil Casing	1
Kit	32	121-246-11	Gasket (Oil Plug)	1
	33	035-125-13	Oil Plug	1
Kit	34	121-000-20	Gasket (O.Casing/P.Casing)	1
	35	140-256-13	Socket Bolt	3
SR	36	122-441-11	V-Ring	1



TOYO PUMPS NORTH AMERICA CORPORATION

2853 Douglas Road
 Burnaby, BC V5C 6H2
 Tel: (604) 298-1213 Fax: (604) 298-1224

Kit ITEMS ARE INCLUDED IN GASKET KIT
 SR ITEMS ARE INCLUDED IN SEAL REPAIR KIT

PARTS LIST - DL1-110

Ref. Dwg. No. A6763 Rev.1

TPSD-001 Rev.0

Please use the part number when ordering.

Effective: June 29, 2009

	REF #	PART #	DESCRIPTION	QTY
SR	37	071-292-14	Shaft Sleeve	1
	38	021-001-34	Impeller (60Hz)	1
	38	021-001-35	Impeller (50Hz)	1
	39	142-143-12	Washer	1
	40	040 417 00 02037	Spring Washer	1
	41	024-000-02	Agitator	1
	42	140-057-12	Bolt	2
	43	032-289-17	Hose Coupling NPT 2" (45 deg.) (STD.)	1
	43	032-144-19	Hose Coupling Barb 2"	1
Kit	44	121-138-19	Gasket (Discharge Fitting)	1
	45	020-000-40	Pump Casing	1
	46	142-143-12	Washer	2
	47	141-030-12	Acorn Nut	2
	48	023-00046	Strainer Stand	1
	49	140-062-10	Bolt	3
**	SR	952 200 09 11915	Seal Repair Kit (includes gasket kit)	1
SR	Kit	173-550-12	Gasket O-Ring Kit	1set