



PL-2 Pump Data

Net Weight	92kg (203lbs)
Shipping Weights	114kg (252lbs)
Impeller Diameter	158.75mm (6 1/4")
RPM	From 1150 RPM to 2900 RPM
Max Solids	44.45mm (1 3/4")

Self-Priming Head

1150 RPM	7.3m (24ft)	-	1450 RPM	7.6m (25ft)
1750 RPM	7.6m (25ft)	-	2050 RPM	7.6m (25ft)
2350 RPM	6.1m (20ft)	-	2650 RPM	7.6m (25ft)
2650 RPM	6.7m (22ft)	-	2900 RPM	7.6m (25ft)

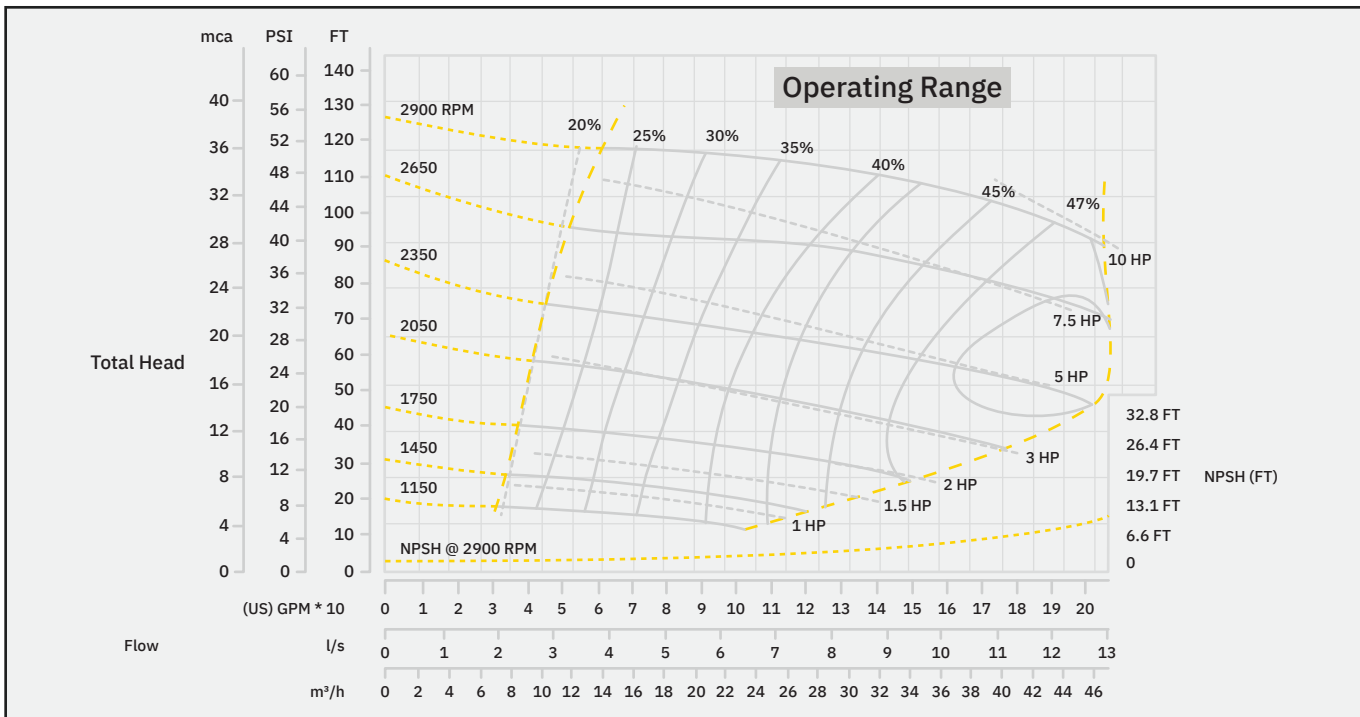

Performance Curve: 2" X 2"

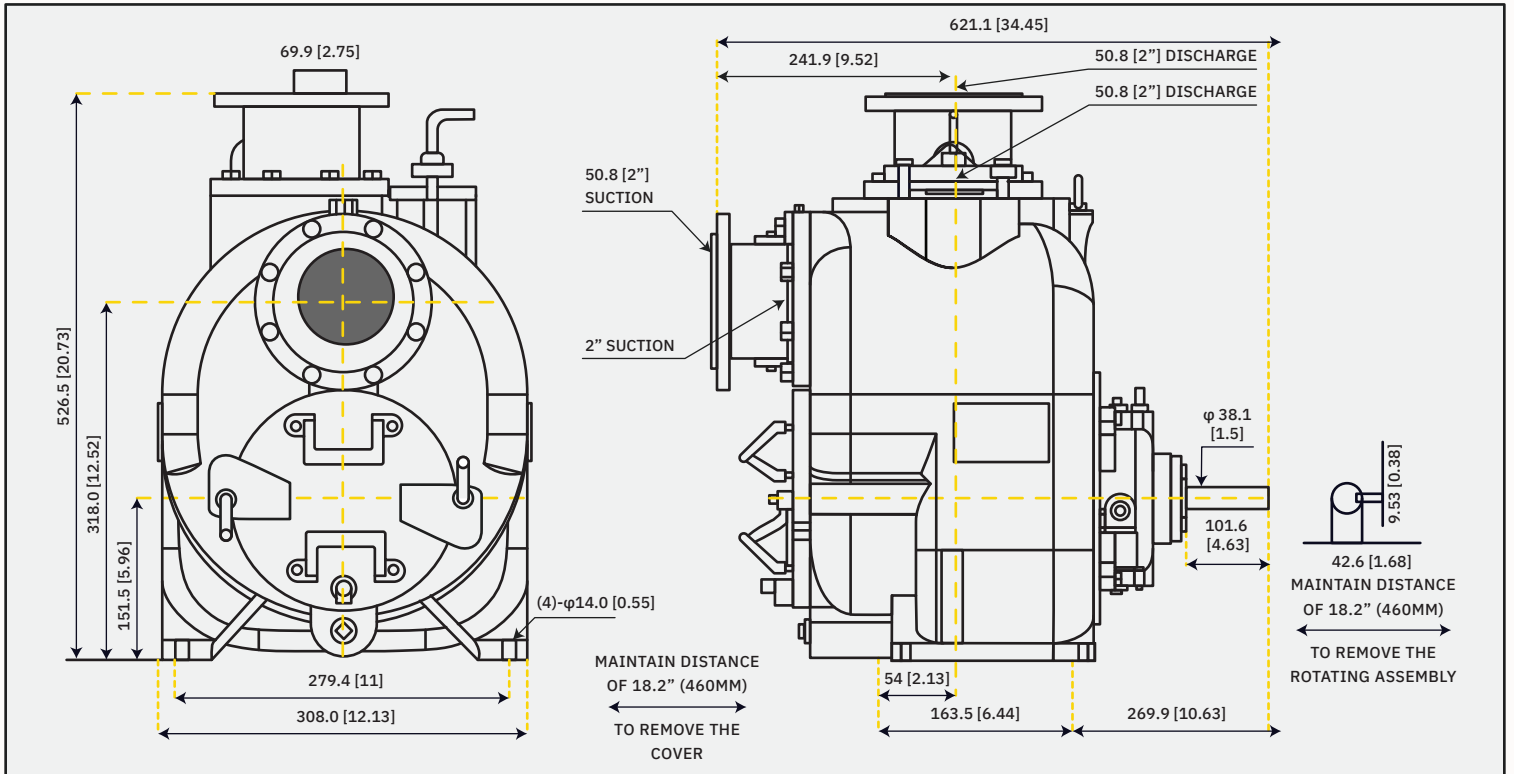

Component	STD	CI / 316SS	CI / CD4MCU	CI / ADI	CI / HCI	ADI	316SS	CD4MCU
Casting		A48CL30				ADI	316SS	CD4MCU
Impeller	A60-40-18	316SS	CD4MCU	ADI	HCI	ADI	316SS	CD4MCU
Wear Plate	A48CL30	316SS	CD4MCU	ADI	HCI	ADI	316SS	CD4MCU
Cover Plate		A48CL30				ADI	316SS	CD4MCU
Bearing Housing		A48CL30				ADI	316SS	CD4MCU
Seal Plate	A48CL30	316SS	CD4MCU	ADI	HCI	ADI	316SS	CD4MCU
Flap Valve		Neoprene				Viton		
Impeller Shaft	ANSI414OHT					ANSI17-4PH		
Seal Sleeve	ANSI414OHT					ANSI17-4PH		
Flanges		A48CL30				ADI	316SS	CD4MCU
O Rings		Buna				Viton		
Mechanical Seal		316SS, Buna, Tungst/Titanium Carbide				316SS, Viton, Tungst/Titanium Carbide		

Materials of Construction