



XT-4 Pump Data

| | |
|-------------------|--------------------------|
| Net Weight | 259.5kg (600lbs) |
| Shipping Weights | 280kg (655lbs) |
| Impeller Diameter | 247.65mm (9 3/4") |
| RPM | From 650 RPM to 1950 RPM |
| Max Solids | 76.2mm (3") |

Self-Priming Head

| | | | | | |
|----------------------|---|----------------------|----------------------|---|----------------------|
| 650 RPM 1.5m (5ft) | - | 750 RPM 2.4m (8ft) | 1450 RPM 6.4m (21ft) | - | 1550 RPM 6.4m (21ft) |
| 850 RPM 4.9m (16ft) | - | 950 RPM 5.8m (19ft) | 1650 RPM 6.7m (22ft) | - | 1750 RPM 6.7m (22ft) |
| 1050 RPM 6.7m (22ft) | - | 1150 RPM 7.3m (24ft) | 1850 RPM 7.6m (25ft) | - | 1950 RPM 7.6m (25ft) |
| 1250 RPM 7.6m (25ft) | - | 1350 RPM 7.6m (25ft) | 2050 RPM 7.6m (25ft) | - | 2150 RPM 7.6m (25ft) |

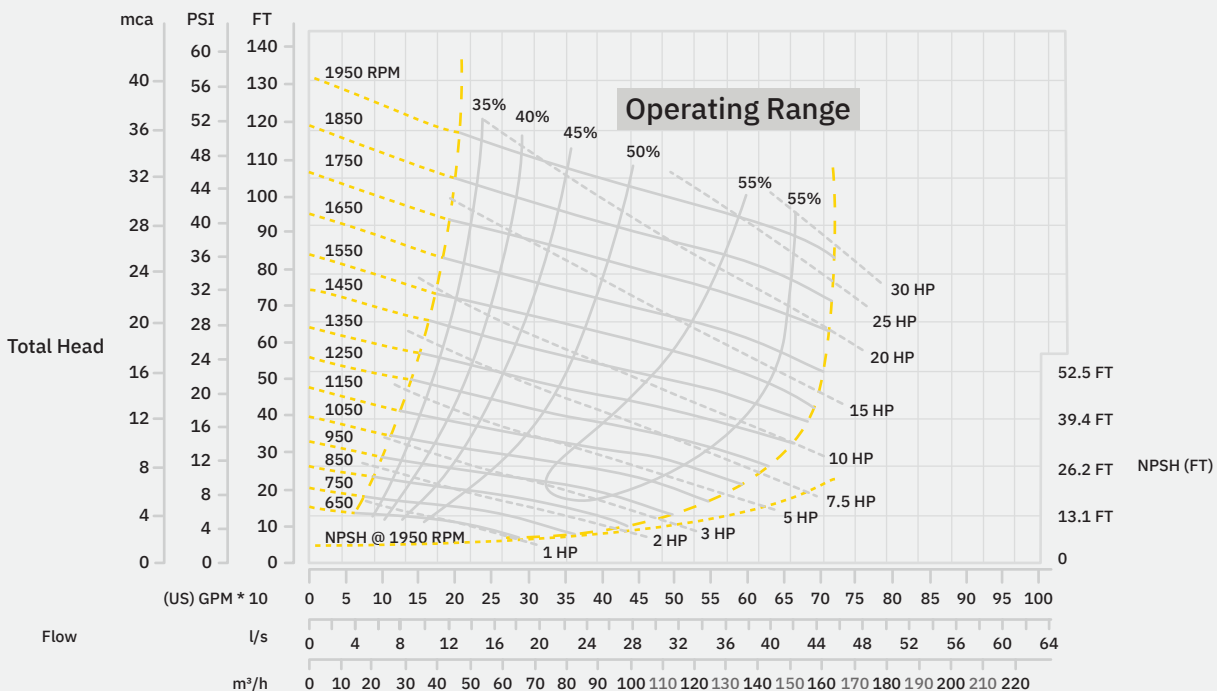

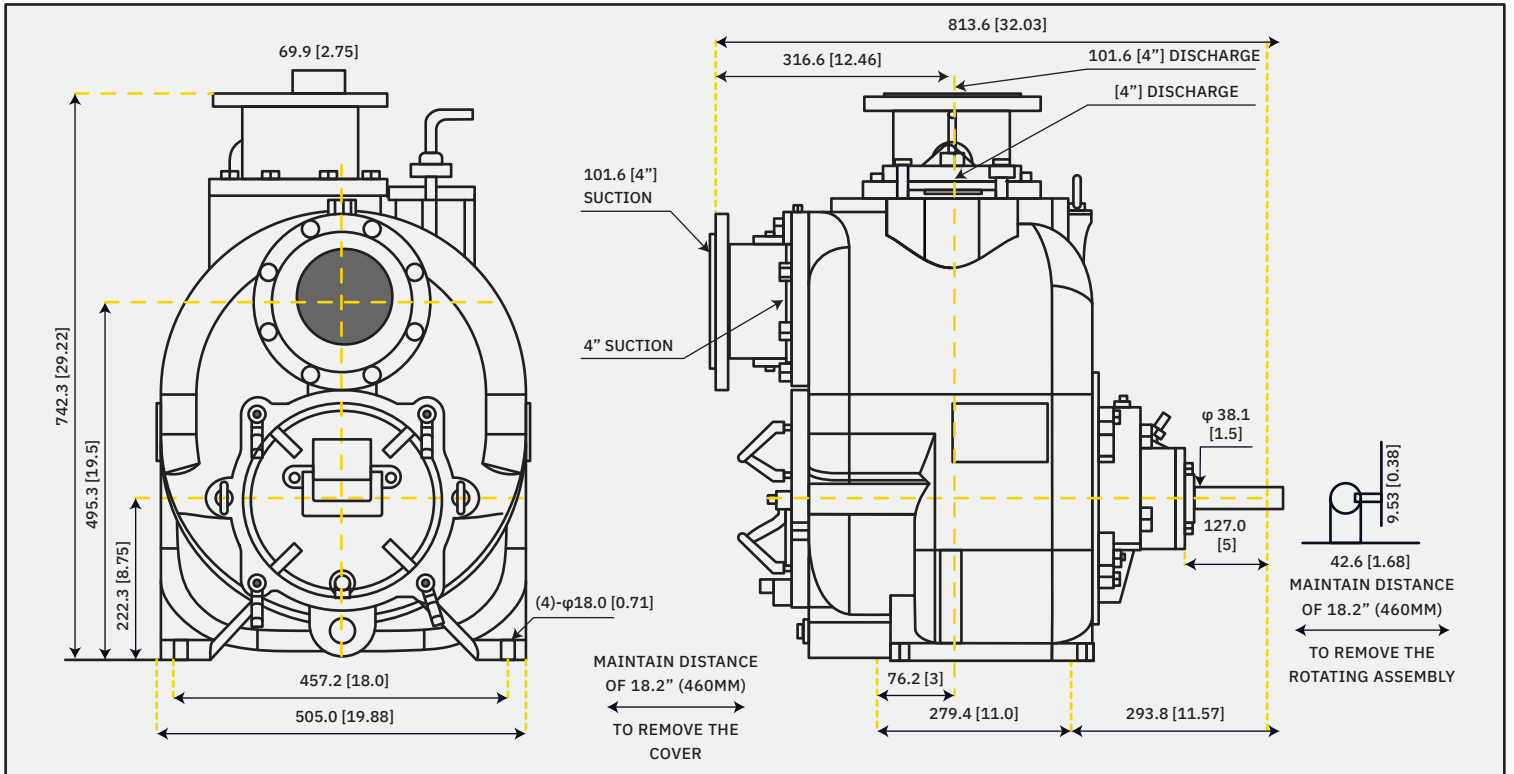

| Component | STD | CI / 316SS | CI / CD4MCU | CI / ADI | CI / HCI | ADI | 316SS | CD4MCU |
|-----------------|------------|-------------------------------------|-------------|----------|----------|--------------------------------------|-------|--------|
| Casting | | A48CL30 | | | | ADI | 316SS | CD4MCU |
| Impeller | A60-40-18 | 316SS | CD4MCU | ADI | HCI | ADI | 316SS | CD4MCU |
| Wear Plate | A48CL30 | 316SS | CD4MCU | ADI | HCI | ADI | 316SS | CD4MCU |
| Cover Plate | | A48CL30 | | | | ADI | 316SS | CD4MCU |
| Bearing Housing | | A48CL30 | | | | ADI | 316SS | CD4MCU |
| Seal Plate | A48CL30 | 316SS | CD4MCU | ADI | HCI | ADI | 316SS | CD4MCU |
| Flap Valve | | Neoprene | | | | Viton | | |
| Impeller Shaft | ANSI4140HT | | | | | ANSI17-4PH | | |
| Seal Sleeve | ANSI4140HT | | | | | ANSI17-4PH | | |
| Flanges | | A48CL30 | | | | ADI | 316SS | CD4MCU |
| O Rings | | Buna | | | | Viton | | |
| Mechanical Seal | | 316SS, Buna, Tungs/Titanium Carbide | | | | 316SS, Viton, Tungs/Titanium Carbide | | |

Materials of Construction